



Thank you for your purchase of this glider in the **Weston Collection®** of outdoor benches, swings and accessories. Every step has been taken to make this the best looking longest lasting bench in the market today. The growing Weston Collection can be seen at www.paintedskydesigns.com



Assembly Instructions

Step 1. Seat assembly. Holding the side frame sections in place, attach the backrest with 4 bolt/nut combos. Do not tighten. Position the seat section in place and secure with the short bolts from the bottom side. Tighten all bolts.

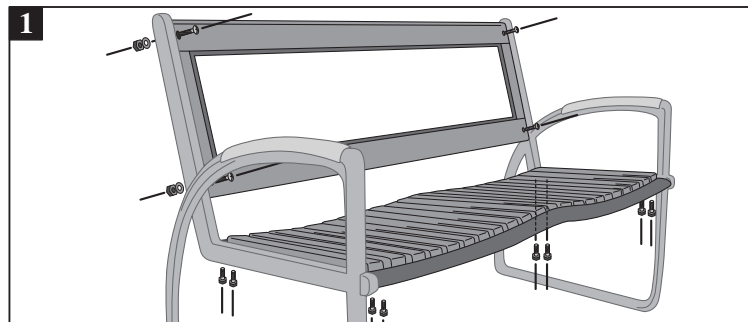

Step 2. Base assembly. Holding base frame sections in place, attach base crossmembers as shown in illustration 2 using two short bolts for each side. Tighten.

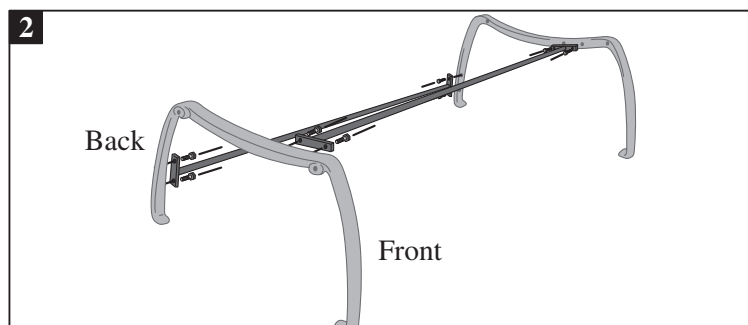

Step 3. Attach the swing bars to the *outside* of the base frame as shown using the long bolts.

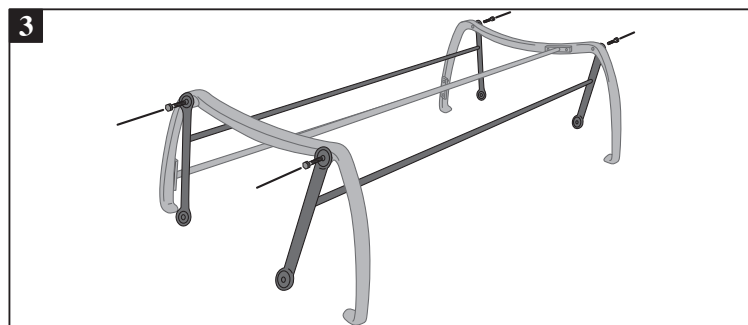

Step 4. Lower the completed seat section carefully over the base. Using the long bolts, attach the seat side frame to the lower ends of the swing bars. Note that the section of the base frame containing the lowest crossmember bar is the back side.

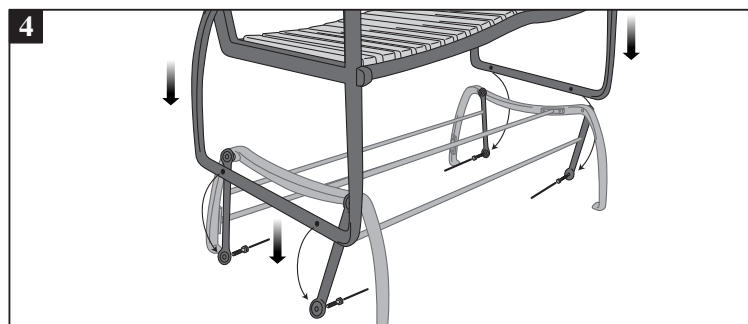

IMPORTANT! Cast iron products should *never* be dragged across any surface. Doing so will likely break the base frame or cause a fracture, resulting in future breakage. For this reason, we can only our warranty the product to be free of defect at the time of assembly.

Parts List

Cast iron base frame	2
Cast iron backrest/wood frame	1
Seat section	1
Side frame	2
Base crossmembers	2
Swing bars	2
Mounting hardware	
Long bolts	8
Short bolts	16
Nut/bolt combo	4

Note: While the glider can be assembled by one person, a second set of hands will help considerably.